



“I.C. ENGINE CYLINDER FINS TRANSIENT THERMAL ANALYSIS BY USING ANSYS SOFTWARE”

¹Dr. A.K.S. Ansari, ²Dr. G. Mahesh, ³Mrs. T.Nina, ⁴Mrs. L. Priyanka,

¹Professor, Dept. of Mechanical Engineering, Malla Reddy College of Engineering, Sec-100

²Associate Professor, Department of Mechanical Engineering, Malla Reddy College of Engineering, Sec-100

³Asst. Professor, Department of Mechanical Engineering, Malla Reddy College of Engineering, Sec-100

⁴Asst. Professor, Department of Mechanical Engineering, Malla Reddy College of Engineering, Sec-100

Abstract— The cooling mechanism of the air cooled engine is mostly dependent on the fin design of the cylinder head and block. Cooling fins are used to increase the heat transfer rate of specified surface. Engine life and effectiveness can be improved with effective cooling. The main aim of the project is to study and comparing with 100 cc Hero Honda Motorcycle fins and analyzes the thermal properties by varying geometry, material and thickness. Parametric models of cylinder with fins have been developed to predict the transient thermal behavior. Presently Material used for manufacturing the models is aluminum alloy 6063 which has thermal conductivity of 200W/mk. We are analyzing the designed models by taking the thermal temperature of 100 degrees centigrades. The energy transfers from the combustion chamber of an internal combustion engines are dissipate in three different ways. Transient thermal analyses were performed for actual and proposed design of engine cylinder in order to optimize geometrical parameters and enhanced heat transfer from the IC engine. Result revel that the proposed design of IC engine has better performance and heat transfer rate from the heating zone in the IC engine that is why the result of present work is more concentrate on it and also proposed replacement of new design by Using ANSYS 17.0 software.

Key words: Internal Combustion engine, transient thermal analysis, CATIA, ANSYS,

Heat Transfer, Aluminum

. INTRODUCTION

Most combustion engines or internal combustion engines are fluid cooled using either air (aeriform fluid) or a liquid agent like water run through a device (radiator) cooled by air. In air cooling system, heat is carried out or driven away by the air flowing over and round the cylinder. Here fins are sew the plate and cylinder barrel which offer extra heat conductive and heat radiating surface. In water cooling system of cooling engines, the cylinder walls and heads are given jacket Cooling fins facilitate keep Chevrolet potential unit battery at ideal temperature we all know that just in case of internal combustion (IC) engines, combustion of air and fuel takes place within the engine.



FIG. 1

Types of Cooling System

There are primarily Two types of cooling systems:

1. Air cooled system, and
2. Water cooled system.

II. METHODOLOGY

Step 1: Aggregation data and information associated with cooling fins of IC engines. Step 2: A completely parametric model of the cylinder block with fin is formed in CATIA ver 5.0 software package.

Step 3: Model obtained in Step a pair of is analyzed using ANSYS17.0 (Workbench), to get the warmth or heat rate , thermal gradient and nodal temperatures.

Step 4: Manual calculations are done. Step 5: Finally, we tend to compare the results obtained from ANSYS and manual calculations for completely different material, shapes and thickness.

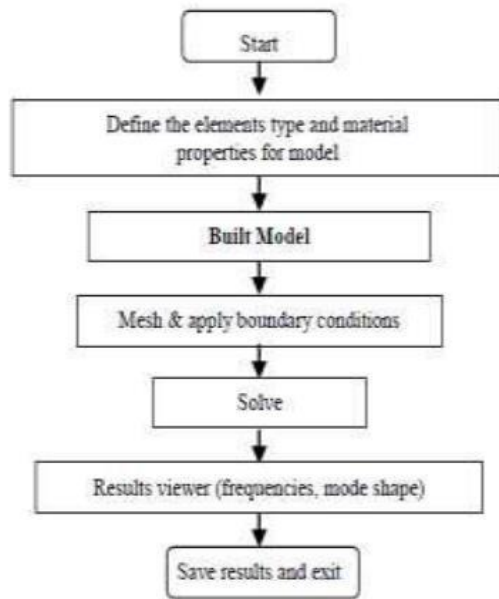

FIG. 2
FIN EQUATION

The purpose of fins in IC engine is to boost convective heat transfer from engine. The first purpose behind the operation of fins is to boost the effective heat transfer space from the surface. A balance of energy is performed on this component within which it's assumed that the component is at constant and uniform temperature of T.

Where C₁ and C₂ are constant that can be determined from the boundary conditions.

Case I: The fin is very long and the temperature at the end of the fin is approach to the temperature of the surrounding T_∞.

Conductive heat transfer at the base of fin, according to Fourier's law

$$Q_{Fin} = -kA \left(\frac{dT}{dx} \right)_{x=0}$$

$$Q_{Fin} = \sqrt{hPkA}(T_0 - T_\infty)$$

K = 200 w/mk = 0.2 w/mm k

h = 5 x 10^{-0.006} w/mm² k

T₀ = 1000 °C

T_∞ = 25 °C

$$Q_{Fin} = \sqrt{hPkA}(T_0 - T_\infty)$$

Width of fins = 1.5 mm

Thickness of fins = 1 mm



1.5mm

$$Q = \sqrt{5 \times 10^{-0.006} \times 2 (1.5 + 1) \times 0.2 \times 1.5 \times 1 \times 975}$$

Q = 2670 watt

Material properties and Boundary Conditions

Engine: 100 cc Hero Honda Aluminum Alloy 6063

Thermal conduction K = 200 W/m-K=0.2 W/mm-K

Specific heat Cp = 0.9 J/g0C = 900 J/Kg-K
Density = a pair of 2.7 g/cc = 2700 kg/m³= 0.000027 kg/mm³

Boundary Condition:

Ambient Temperature: 250

Cylinder Internal temp. = 1000 0C

Heat Flux = 22 W/mm²

III. SIMULATION
EXITING MODEL

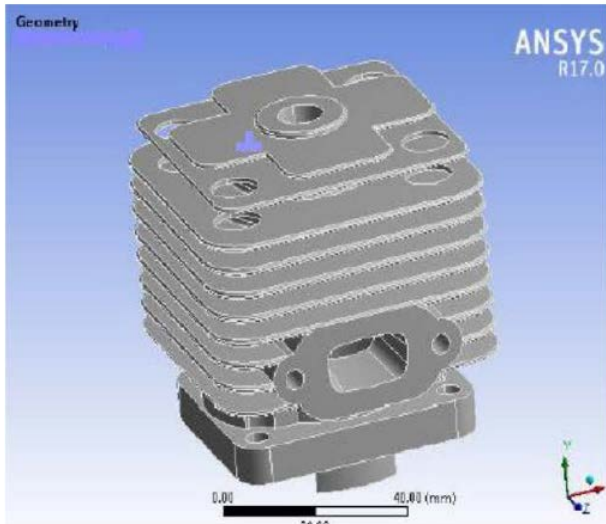

Fig.04

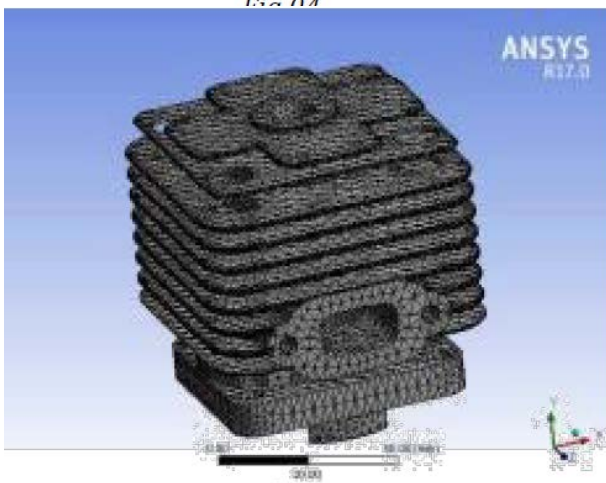

Fig.05

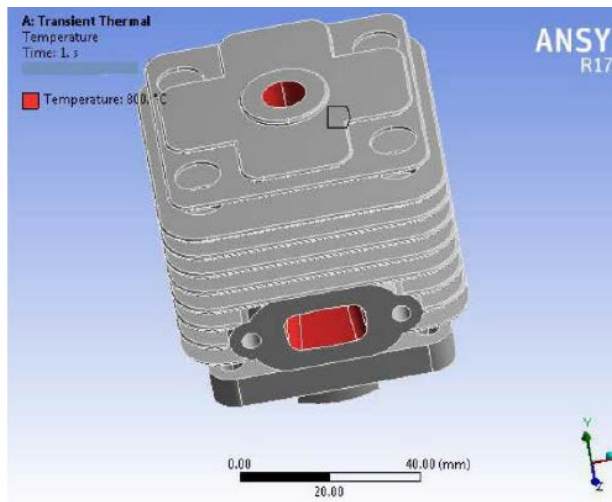

Fig.06

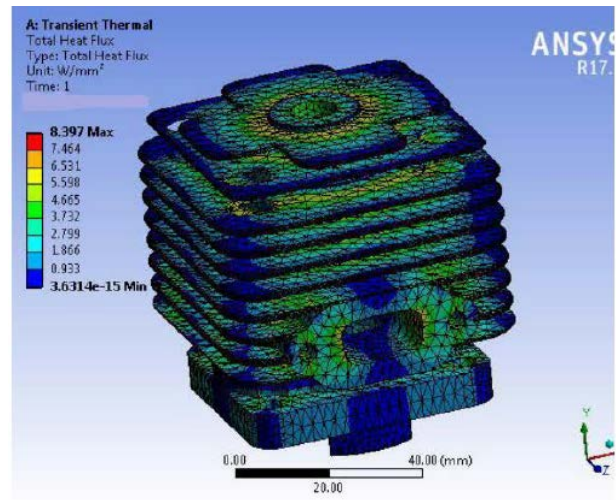

Fig.07

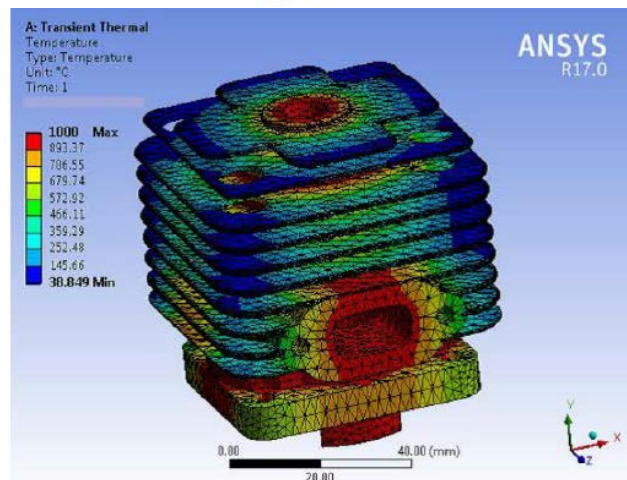

Fig.08

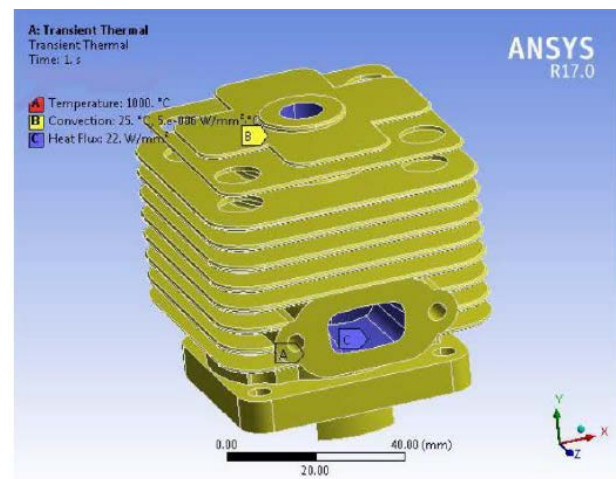

Fig.09

PROPOSED MODEL

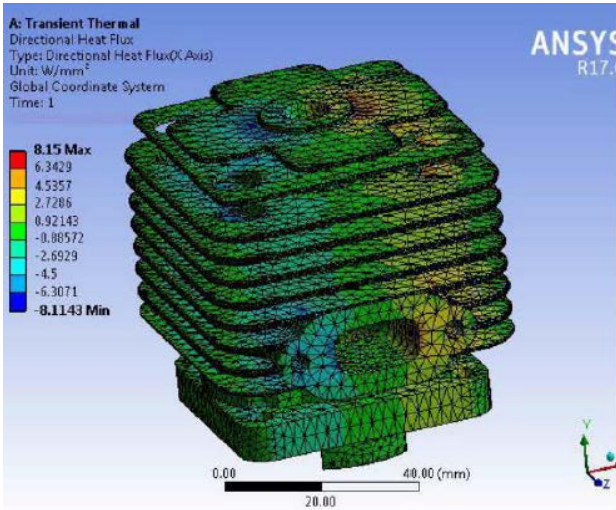

Fig.10

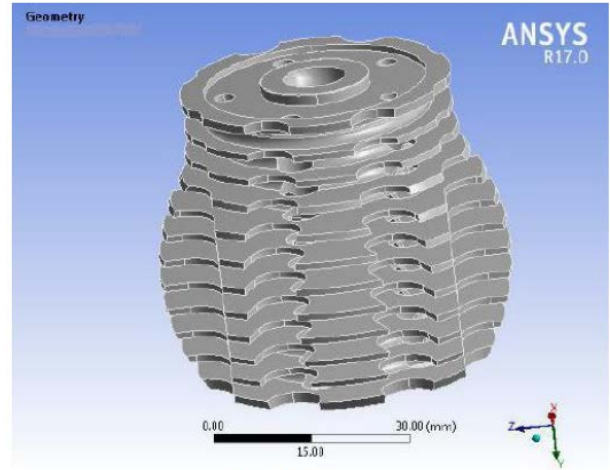

Fig.13

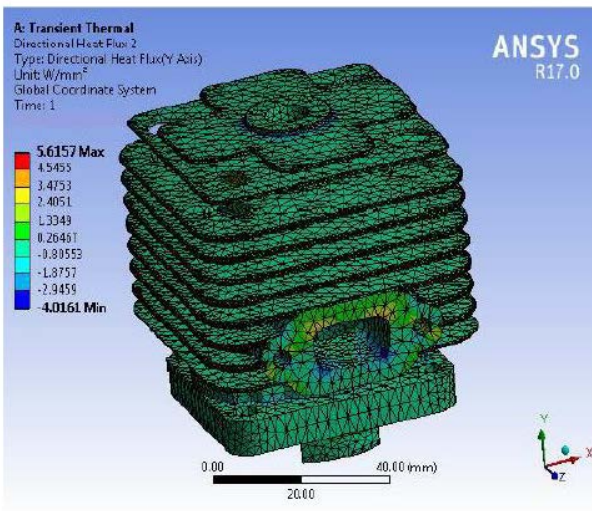

Fig.11

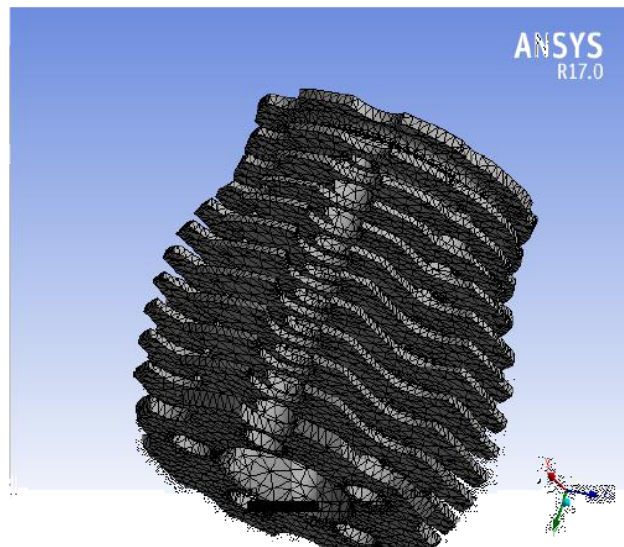

Fig.14

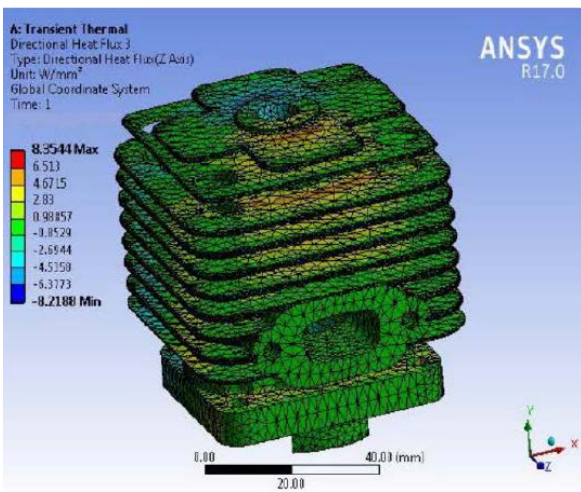

Fig.12



Fig.15

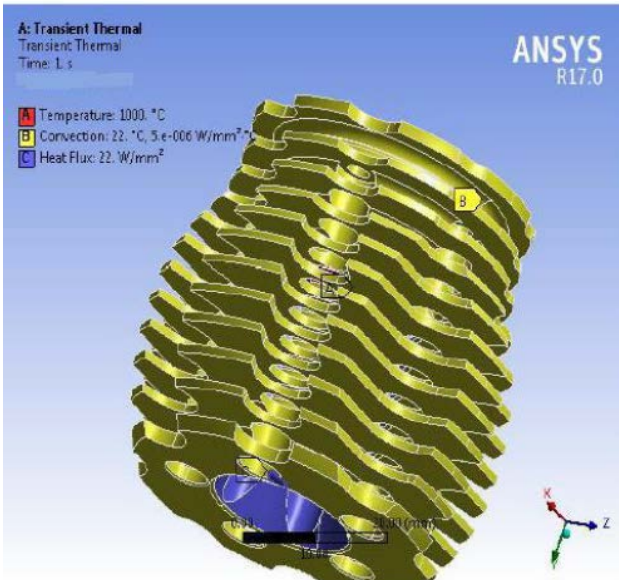

Fig.16

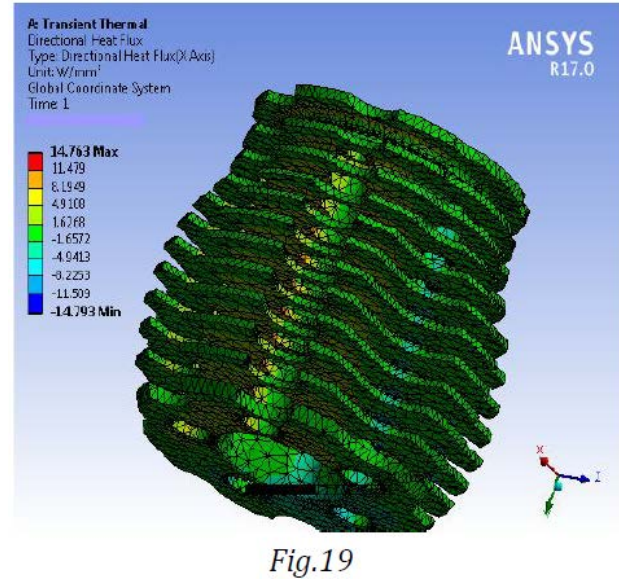

Fig.19

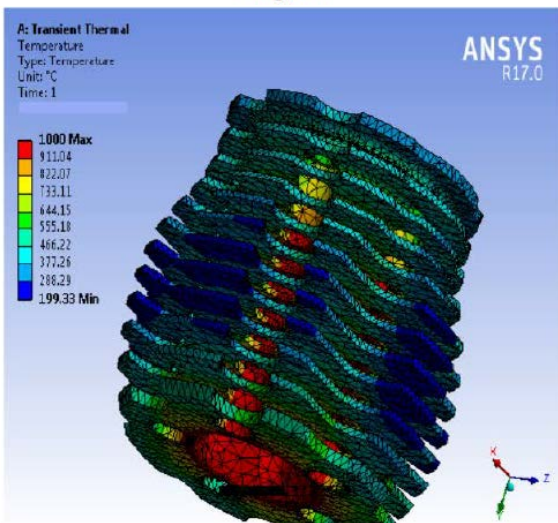

Fig.17

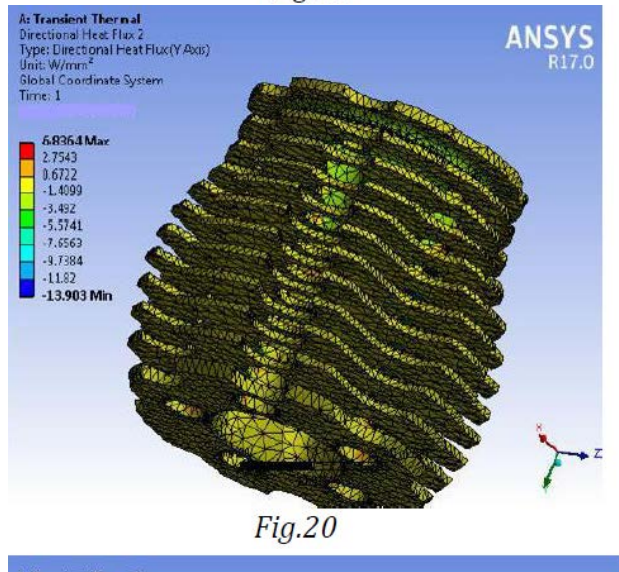

Fig.20

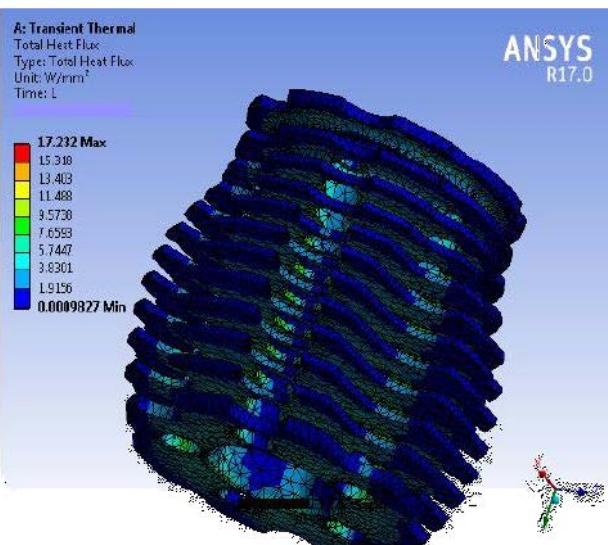

Fig.18

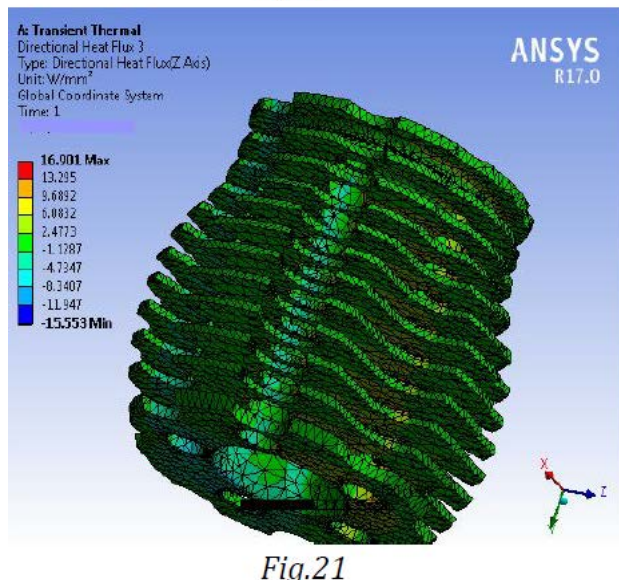

Fig.21

Table.1

S.NO	Temp(⁰ C)	Exitin g Model	Propose d Model
Temp(⁰ C)	Max	1000	1000
	Min	38.84	199.33
Total Heat (w/mm2)Fl ux	Max	8.397	17.2
	Min	3.63E-15	9.83E-04
Directional Heat Flux(w/mm 2) (X Direction)	Max	8.15	14.76
	Min	-8.11	-14.79
Directional Heat Flux(w/mm 2) (Y Direction)	Max	5.6	6.8
	Min	-4.0	-13.9
Directional Heat Flux(w/mm 2) (Z Direction)	Max	8.3	16.9
	Min	-8.2	-15.5

Transient thermal analyses were performed for actual and projected design of engine cylinder so as to optimize geometrical parameters and increased heat transfer from the IC engine. Within the present work transient thermal analysis is performed on actual style and additionally on two completely different geometrical styles at close temperature 25 °C. The subsequent points are recognized within the variety of conclusive statements that are as follows.

1.The results of transient thermal analysis of actual design of engine cylinder at close temperature 26oC indicates the utmost temperature is 1000 oC and minimum temperature is 199.3 oC, most enthalpy flux generated is 17.2 W/mm2 and minimum heat flux generated is 9.83E-04 W/mm2, most Directional heat flux in Y-direction generated is 13.2 W/mm2 and minimum Directional heat flux generated is -7.46 W/mm2

2.The results of transient thermal analysis of proposed model of engine cylinder at close temperature 25 °C indicates the utmost temperature is 1000°C and minimum temperature is 167.8 °C, most total heat flux generated is 27.8 W/mm2 and minimum heat flux generated is 0.002828 W/mm2, the utmost directional heat flux in X-direction generated is 14.76 W/mm2 and minimum directional heat flux generated is -14.79 /mm2 , directional heat flux in Y-direction generated is 6.8 W/mm2 and minimum Directional heat flux generated is -13.9W/mm2 and directional heat flux in Z-direction generated is 16.9 W/mm2 and minimum Directional heat flux generated is -15.5 W/mm2.

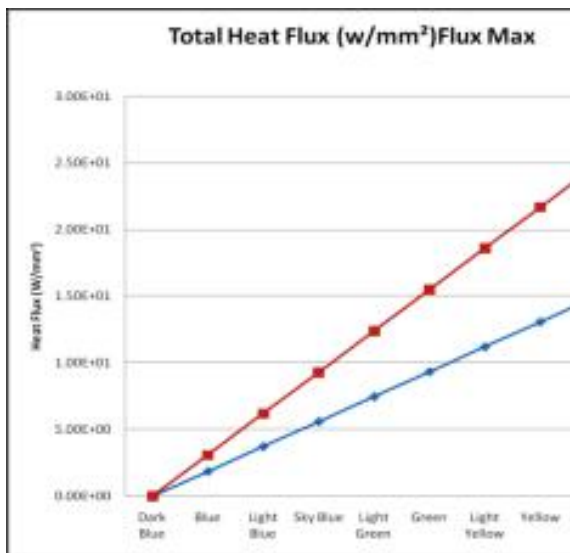

FIG.22

IV. RESULT & DISCUSSION

The transient thermal analysis were performed using an analytical software package ANSYS worktable supported finite volume analysis. The consequences of various vital geometrical parameters for the transient natural convective heat transfer rate from each actual and projected style of engine.

V. CONCLUSION

During this paper we've got designed a cylinder fin body used n a 100cc Hero Honda motorbike and 3D modeling software package CATIA ver 5.0 and used material for fin body is metallic element alloy fins and internal core with gray forged iron. We have a tendency to are commutation with metallic element alloy 6063 for entire body. the form of the fin is rectangular;

we've got modified the form with circular geometry formed. To summarize this conclusion, the projected style of IC engine has higher performance and heat transfer rate from the heating zone within the IC engine that's why the results of present work is additional focus on it and additionally projected replacement of recent style.

VI. FUTURE SCOPE:

The aim of gift work to extend heat transfer rate from the heating zone in IC engine, for that transient thermal analysis are performed on actual style of Hero Honda 110 CC single cylinder engine. There are some doable future works which can be doable for more analysis;

1. Radiation analysis also can be performed for constant work.

2. Altogether sorts of analysis within the present work the fabric used for casting is Al alloy; another material may used.

3. CFD analysis also can be done to grasp air flow round the casting.

REFERENCES

[1] Shubham Shrivastava & Shikar Upadhyay "Thermal Analysis of IC Engine Cylinder Block with Fins Perpendicular to the Axis of Piston Movement" International Journal of Mechanical and Industrial Technology ISSN 2348-7593 (Online) Vol. 3, Issue 2, pp: (139-149), Month: October 2015 - March 2016.

[2] Vinay Kumar Attar & Himanshu Arora "Transient Thermal Analysis of Internal Combustion Engine Piston in Ansys Workbench By Finite Element Method" International Journal of Engineering Sciences & Research Technology, ISSN: 2277- 9655 Attar* et al., 5(6): June, 2016.

[3] Chidiebere Okeke-Richard & Sunny Sharma " Thermal Analysis and Comparison of Cylinder Blocks of 4S, SITwo Wheeler Engine Using ANSYS" International Journal of Innovative Science, Engineering & Technology, ISSN 2348 – 7968 Vol. 3 Issue 5, May 2016.

[4] G. Bahadur Vali & Krishna Veni

"Design/Modeling and Thermal Analysis on Cylinder Head of I.C Engine" International Journal & Magazine of Engineering, Technology, Management and Research, ISSN No. 2348- 4845 Volume No.03 (2016), Issue No.05 (may).

[5] Abhishek Mote at el "Analysis of Heat transfer through fins of an IC Engine using CFD" International Research Journal of Engineering and Technology (IRJET) e- ISSN: 2395 -0056, p- ISSN: 2395-0072 , Volume: 03 Issue: 04 | Apr-2016. [6] KM Sajesh, Neelesh Soni and Siddhartha Kosti "Design Modification and Heat Transfer Analysis of Air Cooled Rectangular Fin Engine" International Journal of Recent Scientific Research ISSN: 0976-3031 Volume: 7(3) March - 2016.

[7] Mr. Manir Alam & Mrs. M. Durga Sushmitha "Design and Analysis of Engine Cylinder Fins of Varying Geometry and Materials" International Journal of Computer Engineering In Research Trends, ISSN (O): 2349-7084 Volume 3, Issue 2, February- 2016, pp. 76-80.

[8] Swati Saini & Kagdi Dhruvin Nileshkumar "Comparison of CFD Analysis of Heat Transfer Augmentation & Surface Heat Transfer Co efficient of I. C. Engine Fins at Different wind Velocities with Experimental Investigation" International Journal for Scientific Research & Development| Vol. 4, Issue 03, 2016 | ISSN (online): 2321- 0613.

[9] P.T. Nitnaware & Prachi S. Giri "Design Optimization Of An Air Cooled Internal Combustion Engine Fin Using CFD" Journal of Multidisciplinary Engineering Science and Technology (JMEST) ISSN: 3159- 0040 Vol. 2 Issue 11, November - 2015.

[10] H. Sumithra & B. Sandhya Rani "Design Optimization and Transient Thermal Analysis of Four Stroke Petrol Engine Cylinder Head" International Journal of Emerging Technology in Computer Science & Electronics (IJETCSE) ISSN: 0976- 1353 Volume 18 Issue 2 – NOVEMBER 2015.

[11] M Syamala Devi, E Venkateswara Rao & K Sunil Ratna Kumar "Optimization of Engine

Cylinder Fin by Varying its Geometry and Material" International Journal of Science and Research (IJSR) ISSN (Online): 2319-7064, Paper ID: SUB159073 , Volume 4 Issue 10, October 2015.

[12]Athirah Abdul Aziz, Adlansyah Abd Rahman and Abdul Aziz Hassan "Design of Customized Modular Cylinder Head for Si-Engine" ARPN Journal of Engineering and Applied Sciences ISSN 1819-6608, VOL. 10, NO. 17, SEPTEMBER 2015.

[13]Gokul Karthik "Design Modification and Analysis of Fins in Two Wheeler Engines by CFD" International Journal of Research in Electrical and Electronics Technology (IJREET) Volume 2 - Issue 1 August 2015.

[14]Shamim Alam & Dr. Gaurav Tiwari "Increase the Efficiency of Internal Combustion Engine Fin by Replacing the Conventional Fin with Parabolic Fin" International Journal of Analytical, Experimental and Finite Element Analysis (IJAEFEA), Issue. 2, Vol. 2, June 2015. e-ISSN: 2394-5141, ISSN: 2394-5133, pp 80-84.

[15]Ashwin Shridhar, Asokan Ram Deepak, S Jayaraj "Int. Journal of Engineering Research and Applications " Conjugate Heat transfer Analysis of helical fins with airfoil cross section and its comparison with existing circular fin design for air cooled engines employing constant rectangular cross-section, ISSN : 2248- 9622, Vol. 5, Issue 6, (Part -5) June 2015, pp.88